

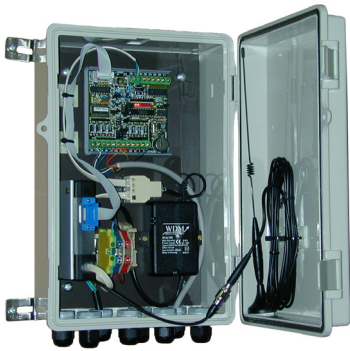

Data Loggers & Remote Monitoring Equipment

Remote SMSlog/flow Diallers (RSD)

ver 1.0



Ordering Code	Description
RSD-GSM-L	Remote Datalogger and Alarm Event Monitoring Device. 4 digital inputs, 4 analogue/digital inputs, 5 outputs. Alarm reporting, Status checking via SMS or GSM modem. Remote upload/download via GSM modem.
RSD-GSM-F	Remote Datalogger and Alarm Event Monitoring Device. 1 pump input & 1 flow switch input, 2 digital inputs, 4 analogue/digital inputs, 5 outputs. Pump Failure reporting, Alarm reporting, Output & Status checking via SMS or GSM modem. Remote upload/download via GSM modem.

Introduction

Instead of wondering what's going on at one of your cooling tower sites, wouldn't it be easier to simply sit behind your computer, dial out to the remote equipment, and view what the TDS level is, what the ORP mV level is? How great would it be to download the logged data to analyse the TDS or mV for the past month? Imagine how simple it would be if you could sit in your office and switch on the biocide pump for 5 minutes, or be told if there is no chemical in one of the tanks? Imagine being told remotely if your biocide pump is not working? Well, now is the time to stop imagining, and to add a Remote SMSlog or SMSflow Dialler to your equipment on-site. Installation is simple as no dedicated modem or telephone line is required.

The RSD (Remote SMSlog or SMSflow Diallers) are data loggers and alarm/event monitors which are interfaced to new equipment or existing equipment already out in the field. An example of equipment would be a DIGICHEM-AB2 cooling tower dosing & control package. The RSD with its internal GSM modem, notifies the occurrence of any alarms/events via SMS, and collects historical data eg TDS or ORP. The equipment status and logged data can be interrogated remotely and RSD outputs can be activated remotely via modem or mobile phone.

Features & Benefits

The features of the RSD are broken down into its 2 components, ie. the Logger component and the SMS Dialler component:

Logger

- 4 channel, 8 bit per channel (each channel logs a variable, eg. TDS, ORP, pH)
- Logging interval programmable from 5 min to 60 min
- Logged data displayed in actual units, eg, TDS, mV or pH
- Remote download of logged data
- Alarm/Events logged in addition to logs at programmable intervals eg. pump status (ie. powered On or Off), High TDS or Low ORP
- Automatic wrapping of data (ie when full, oldest information is lost first)

SMSlog/flow Dialler

- Sends SMS messages of alarm conditions, eg. HIGH TDS or LOW ORP, Tank empty, biocide clock reset (the SMSflow can also monitor up to one pump for loss of prime and SMS if there is no chemical discharge)
- Up to 4 mobile numbers can be SMS'd when an alarm event occurs (configurable per alarm)
- Programmable alarm messages eg, Tank B empty
- Site message sent via SMS with all alarm/event messages, eg, 100 George St Tower 1, Tank B empty
- High and/or Low TDS/pH/mV alarm messages can be sent via SMS
- System status/parameters can be accessed via PC modem or via GSM mobile phone
- LED indication on-site of all alarm/event conditions

Operation

An overview of the operation of the 2 standard models available is outline below:

RSD-GSM-L with SMSlog PCB:

The RSD-GSM-L Remote SMSlog Dialler with SMSlog PCB provides the capability to monitor and control remote equipment via a cellular mobile telephone and the Short Message Service (SMS). Analogue inputs and alarm conditions are logged to non-volatile memory and can be downloaded in CSV format via a PC dial-up. The SMSlog can be configured using a PC and either a direct connection or a dial-up connection. Key operational parameters can be configured via SMS. An alpha-numeric PIN provides security from unauthorised accesses. A dial-up data connection can be made using a standard modem attached to a PC. A graphical user interface (GUI) provides a simple and intuitive way to configure the SMSlog.

The SMSlog has 4 digital inputs, 4 mixed signal inputs (ie. analogue or digital) and 5 digital outputs including local alarm indication. Control algorithms can be implemented using the in-built logic functions and delay timer. Alarms/events are reported using the SMS system.

RSD-GSM-F with SMSflow PCB:

The RSD-GSM-F Remote SMSflow Dialler with SMSflow PCB works the same as the RSD-GSM-L, but can monitor fluid flow in response to valve or pump commands and will generate alarms if flow signals and valve or pump control signals are not correlated. Alarm 1 is generated if there is no flow after the pump starts and while the pump is running. Alarm 2 is generated if there is a false signal from the flow monitor.

The SMSflow PCB has 1 pump input, 1 flow switch input, 2 more digital inputs, 4 mixed signal inputs and 5 digital outputs including local alarm indication. Alarm/events are reported using the SMS system.

RSD Hardware

- Power supply 240VAC/12VDC
- SMSlog or SMSflow printed circuit board (PCB) with screw terminals for 8 inputs and 5 outputs, plus a serial connection
- GSM modem with antenna
- Multi-core lead to wire-up to external equipment (eg ORP controller)
- Spare cable gland entries for auxiliary devices, eg. low level tank switches

RSD Standard Accessories & Software

- Null modem cable (to be able to configure SMSlog/flow PCB directly from a PC/laptop)
- Serial cable (to be able to configure GSM modem with new SIM card directly from a PC/laptop)
- Software to configure and access the RSD
- Software to view and print the configuration of each site
- Software to view and analyse the logged data & logged alarms

Important Note:

The RSD units require a GSM SIM card for remote connection and for SMS to operate. Note that this SIM card must have both a VOICE number and a DATA number. (The RSD requires the VOICE number to send and receive SMS messages, and the DATA number to remotely access the RSD to upload/download the configuration, logged data and the system status). Furthermore, the PIN (password) on the SIM card must be disabled. The easiest way to do this is in a mobile phone (ie when the phone with the SIM card is switched on, it must display the network (eg. YES OPTUS) without having to enter a PIN)

Suggestions for Inputs (to log and/or SMS Alarms/Events)

Digital: Inputs 1-4

(4 max: RSD-GSM-L, 2 max RSD-GSM-F)

- Biocide Pump A activated (logs start time of pump)
- Biocide Pump B activated (logs start time of pump)
- Inhibitor Pump C activated (logs start time of pump)
- Solenoid valve activated (logs opening time of valve)
- Tank Biocide A empty
- Tank Biocide B empty
- Tank Inhibitor C empty
- Power failure
- Timer alarm or Biocide Clock reset

Analogue/Digital: Inputs 5-8 (4 max)

- Biocide Pump A activated (logs start & stop time of pump)
- Biocide Pump B activated (logs start & stop time of pump)
- Inhibitor Pump C activated (logs start & stop time of pump)
- Solenoid valve activated (logs start & stop time of valve)
- Conductivity TDS level plus high and/or low alarms logged
- pH level plus high and/or low alarms logged
- ORP mV level plus high and/or low alarms logged
- Any 4-20mA signal plus high/low alarms logged

Note: the RSD-GSM-F uses Input 1 & Input 2 for monitoring one of the pumps and its flow sensor. This is why you can only select 2 of the above and not 4.

Dimensional Drawing

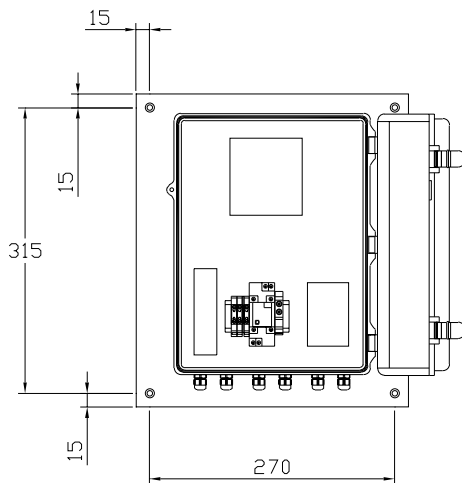

Note: Mounting holes 6mm diameter, countersunk

Electrical Drawing

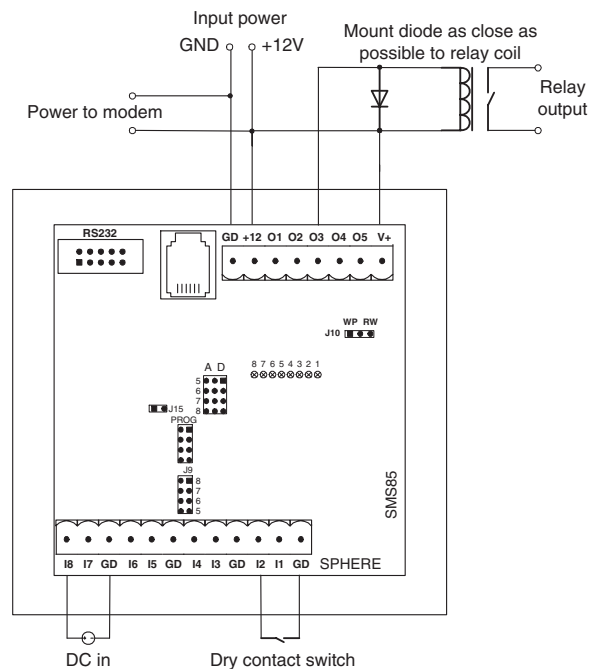

Options & Accessories

Ordering Code	Description
AF04	Flow switch fitted in 20mm Tee
AF10	Card for DIGICHEM controller with Isolated 4-20mA (or 1-5V) & 6 event outputs (NPN open collector): Pump A, Pump B, or Pump C Dosing, Bleed Valve Open, DIGICHEM Alarm activated, DIGICHEM Power Failure
AF10A	Card for DCON-RX controllers with Isolated 4-20mA (or 1-5V) proportional to ORP, & 3 event outputs (NPN open collector): Oxidant Pump eg. dosing Chlorine (or Brominator Dosing Solenoid valve), DCON-RX Alarm activated, DCON-RX Power Failure
AF10B	Card for DCON-PH controllers with Isolated 4-20mA (or 1-5V) proportional to pH, & 3 event outputs (NPN open collector): Acid Pump or Base Pump, DCON-PH Alarm activated, DCON-PH Power Failure
SP-D-EPROM	Updated software for controller to enable AF10, AF10A or AF10B

Options & Accessories (continued)

Ordering Code	Description
LLTS-XXX	Low level tank switch (XXX = length in cm from cap of tank to base of tank (eg. 085=85cm)
HCL1802-AFS-SEFL3	EMEC pump 2l/hr @ 18bar, adjustable stroke & speed, incl. low level tank switch & flow monitor on head discharge - alarms if pump loses prime or float drops
HACL181.4-AFS-SEFL3	EMEC pump 1.4l/hr @ 18bar, Acrylic self-venting head for dosing chemicals such as Sodium Hypochlorite, adjustable stroke & speed, incl. low level tank switch & flow monitor on head discharge - alarms if pump loses prime or float drops
RSD-R1/R2/R3/R4/R5	Relay outputs for RSD (5 max) to be able to remotely activate pumps, valves or other devices

Specifications

	RSD-GSM-L	RSD-GSM-F
PCB		
Mobile Network Connection	GSM	
Protocols Supported	SMS and 9600 Baud data (with data number enabled on SIM card)	
Firmware	SMS85log-GSM	SMSflow-GSM
Digital Inputs	4 switch closure inputs	2 dedicated to pump & flow inputs, 2 switch closure inputs
Mixed Signal Inputs	4 digital switch closure or 8 bit analogue	
Analogue Input Range	0-5VDC or 0-20mA with 250 Ohm shunt (4-20mA compatible)	
Analogue Input Impedance	47kOhm	
Analogue Input Units	Engineering units can be specified for each input	
Analogue Scaling	Full scale and zero offset parameters for each input	
Analogue Alarms	Level or window with selectable hysteresis, selectable inversion	
Input Detection Time	< 1 second with debouncing disabled, 3 seconds with debounce	
Digital Outputs	5 (open-collector, switched to ground when enabled)	
Digital Output Switch Rating	50VDC Max, 100mA max (all outputs active) 500mA Max (1 active)	
Inductive Loads	Outputs have clamping diodes, additional diode at load recommended	
Log Memory Capacity	4000 time-stamped samples	
Log Memory Retention	200 years in absence of power	
Log Acquisition Rate	5, 10,15, 20, 30 or 60 minute intervals between samples	
Wiring Connectors	Screw terminal	
Configuration	SMS, dial-up or direct connection to PC	
Phone Number Capacity	4 mobile numbers, 14 digits long	
Alarm Number Mapping	Each alarm can be sent to any combination of the 4 phone numbers	
Retry Count	1 to 15 retries for each alarm if network unreachable	
Time between retries	20 to 255 seconds	
Site Message	Up to 16 characters prefixed to all alarms	
Alarm Message	Up to 16 characters for each alarm	
RS232 Interface	Rx, Tx, CD & DTR via a 10 pin header (compatible with DE9)	
Form Factor	OEM PCB (W 82.5mm , L 82.5mm, H 20mm)	
Power Requirements	9 to 15VDC, 30 mA (Absolute maximum applied voltage 70VDC)	
Environmental	0°C to 55°C, 5% to 95% RH, non-condensing	
Auxiliary Equipment		
Power Supply	ETM 90-260 VAC, 50-60 Hz input, 12 VDC regulated output	
Antenna	Small adhesive mount antenna with 3 metre cable, FEM connector	
Cellular Modem	ETM 9200 GSM Cellular Modem (Siemens M20 Engine)	
Physical		
Protection	ABS IP66 hinged cabinet (lockable with optional padlock)	
10mm PVC panel	345 (h) x 300 (w) mm	
Packaged dimensions	350mm (l) x 350mm (w) x 200mm (h)	
Packaged weight	4 kg	