

pH Meter & Controller Model: NANO-PCD1

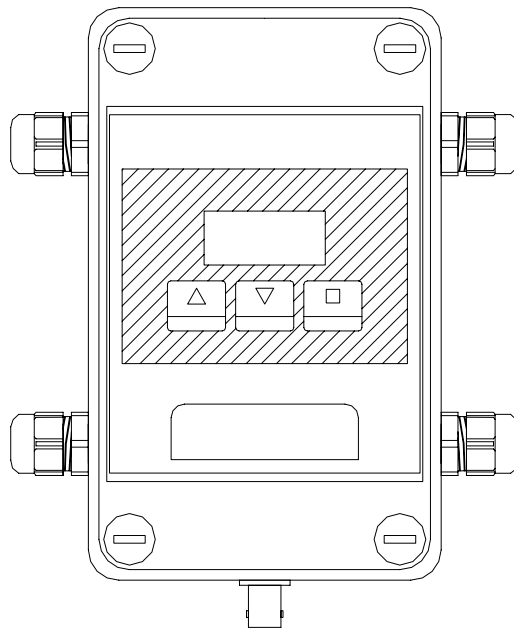

Supplied by:

Convergent Water Controls Pty Ltd

2/4 Huntley Street, PO Box 7058

Alexandria NSW 2015

Tel: (02) 9698 3131

Fax: (02) 9698 3210

www.cwc.com.au

info@cwc.com.au

Manufacturer: Convergent Water Controls Pty Ltd, Sydney Australia.

Note: On-going product development at Convergent Water Controls may lead to changes in the specifications of this product.

Warranty: This product is guaranteed for a period of 12 months from installation date. The warranty applies to manufacturing or component defects which may cause the unit to malfunction under specified conditions. The guarantee does not cover damage due to abuse, tampering or improper installation.

Disclaimer: Convergent Water Controls will not be held liable for any consequential damage or loss arising resulting from product malfunction.

TABLE OF CONTENTS

1. INTRODUCTION	1
1.1 FEATURES	1
2. INSTALLATION	2
2.1 ELECTRICAL WIRING INFORMATION	2
2.2 PROBE INSTALLATION & MAINTENANCE	2
3. COMMISSIONING AND PROGRAMMING SETPOINT	3
3.1 START-UP.....	3
3.2 CALIBRATION.....	4
3.3 SET PH SETPOINT	6
3.4 SET OPERATION	7
3.5 TESTING THE OUTPUT.....	8
4. FACTORY SETTINGS / PROGRAMMABLE OPTIONS	9
5. SPECIFICATIONS	9

1. INTRODUCTION

The NANO-PCD1 measures and controls the pH as read by a pH electrode and can be programmed to dose either an acid or a base chemical.

When acid is dosed into a measured solution, it will cause a decrease in pH. Similarly, when base is dosed, it will cause an increase in pH.

When a dosing pump, injecting acid, is connected to the NANO -PCD1, the pump will dose when the pH rises above the setpoint and will continue to dose until the pH drops below the setpoint.

When a dosing pump, injecting base, is connected to the NANO -PCD1, the pump will dose when the pH drops below the pH setpoint and will continue to dose until the pH rises above the pH setpoint.

Components of a pH Control System are:

1. pH controller (eg. NANO-PCD1)
2. pH probe
3. Suitable Dosing pump (eg. SEKO, EMEC)

1.1 Features

- Simultaneous pH and Setpoint readout on a dot matrix LCD display - instant comparison can be made.
- Programmable Operation feature: Control pH with an Acid or Base.
- Simple 3-button programming. Setting up is simple, easy and accurate!
- Output can be tested at the push of a button - even without connection of the probe.
- Housed in a small and compact mount IP55 enclosure.
- Optional Flow Switch Input.
- Mains 240VAC powered. All programmed parameters are stored in non-volatile memory (EEPROM).

2. INSTALLATION

2.1 Electrical Wiring Information

The diagram below shows the termination of the controller with the electrical terminals at the bottom of the module. Starting from the left, wire the controller as follows:

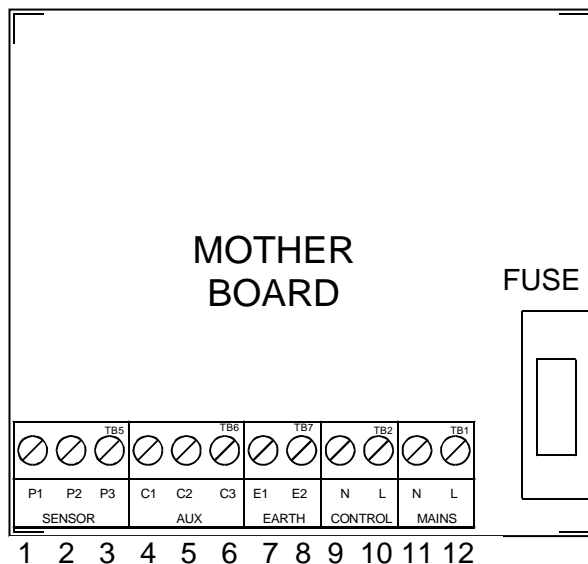

1. pH Electrode Signal (white)
2. pH Electrode Screen (green)
3. Solution ground probe (not used)
4. Common(Optional)
5. Flow Switch(Optional)
6. No Connection
7. Earth
8. Earth
9. Neutral for Solenoid/pump
10. Active for Solenoid/pump
11. Neutral 240VAC supply
12. Active 240VAC supply

Note: Do not remove link between 2 & 3 (i.e. terminals P2 & P3)

2.2 Probe Installation & Maintenance

The pH electrode is the heart of the system. Please take extra care in determining the type and location of the probe. The pH electrode has a high output impedance and is susceptible to interference if not installed correctly.

Plan the installation such that the pH electrode is as close as possible to the controller. If the probe needs to be located further away from the pH controller, an extension cable must be obtained. The further the probe is away from the controller, the greater the effect of electrical interference will be. This may degrade the signal from the probe and causes incorrect readings. Never attempt to extend the probe cable by means of a terminal block or soldered connection. This will leave the connection open to interference or moisture, which will affect the accuracy of the system. Always have the connection (when using an extension cable) in a waterproof junction box.

3.COMMISSIONING AND PROGRAMMING SETPOINT

3.1 Start-Up

After power-up, the NANO-PCD1 controller is ready to perform pH indication and control. All the relevant information is displayed on the LCD display as explained below.

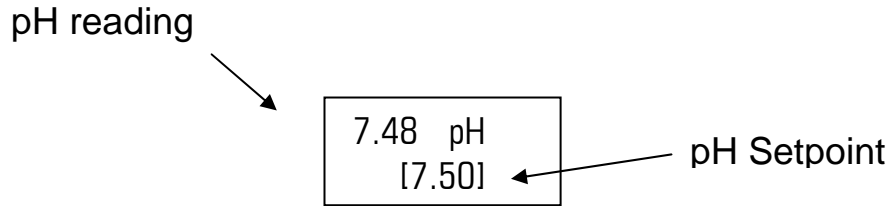

When the output is activated, the display will alternate between:

7.48 pH
[7.50]

and

7.48 pH
[O/P]

Status	Display
Normal operation:	Measured pH & pH Setpoint , as shown above
Programming mode:	Programming information (eg. "Setpoint")

3.2 Calibration

pH7, pH4 and pH10 calibration

Buffer solutions of pH7 as well as pH4 (or pH10) are needed for calibration of this unit. **It is important to calibrate at pH7 first and then at either pH4 or pH10.**

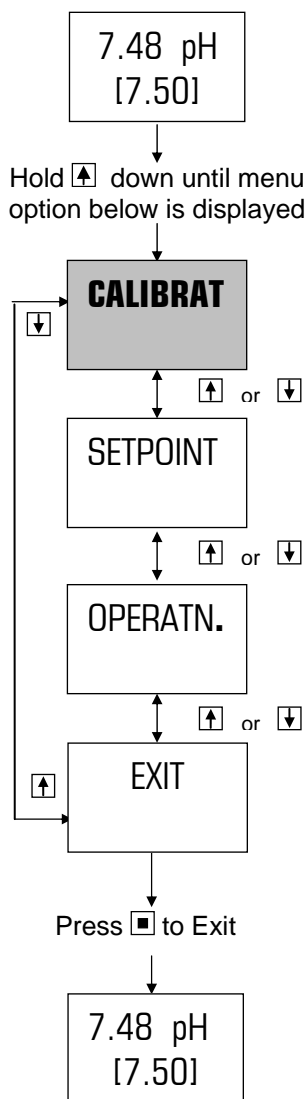

Step 1

Place the probe into the buffer solution (pH7) and enter the calibration menu

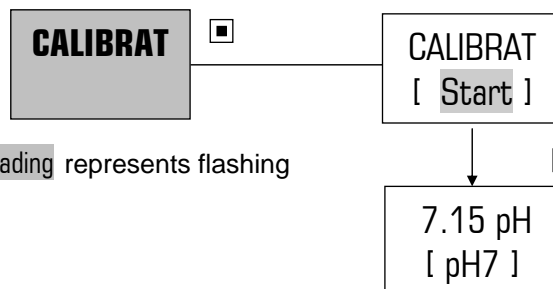

Step 2

Wait for the measured pH reading to stabilise and check if the flashing value between the square brackets corresponds to the buffer solution. If this is true press the ENT button to calibrate the controller. The display should now read:

7.00 pH
[pH7]

Note: If the measured pH still deviates from that of the buffer, press the ENT button again and follow Step 2 again.

Step 3

Immerse the probe in buffer solution of pH4 or pH10. Wait for the measured pH reading to stabilise and check if the flashing value between the square brackets corresponds to the buffer solution. If this is true press the button to calibrate the controller. The display should now read:

4.00 pH [pH4] or 10.00 pH

Note: If the measured pH still deviates from that of the buffer, press the ENT button again and repeat this step.

Step 4

Once calibration has been completed, press either ▲ or ▼ to revert back to normal mode, eg:

7.00 pH
[7.50]

RESETTING CALIBRATION

The controller has factory default calibration values. Should the calibration procedure fails, one can revert back to the factory calibration values. To restore the factory settings, proceed as follows:

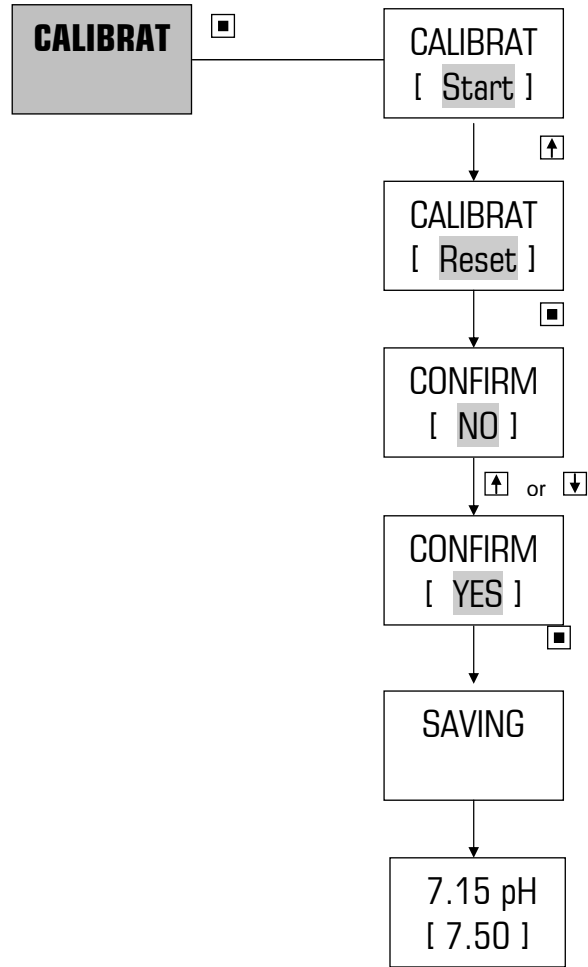
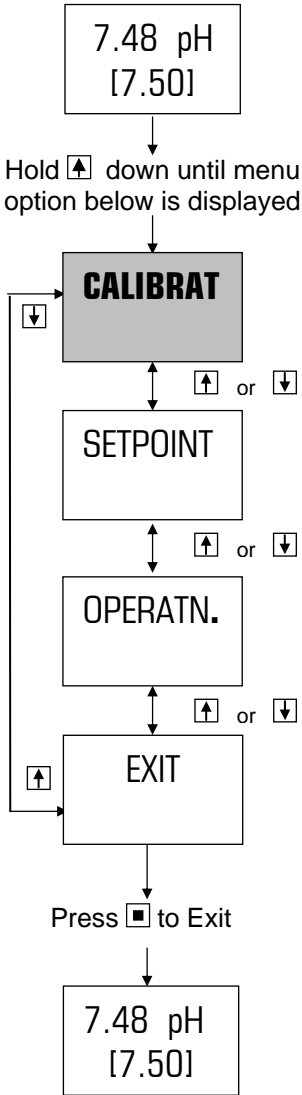

Note: Shading represents flashing

3.3 Set pH Setpoint

The main function of the NANO range of pH controllers is to operate a solenoid valve or dosing pump to maintain pH Setpoint. When the pH of the system tends to increase, the NANO -PCD1 will be programmed to dispense an ACID into the system to bring the pH down, thus maintaining the pH at the programmed Setpoint. When the pH of the system tends to drop, the NANO-PCD1 will be programmed to dispense a BASE into the system to increase the pH.

The setpoint is entered as an actual number (eg. 7.65 pH), in 0.1 pH increments.

Example:

Increasing factory default setpoint of 7.50 pH to a new setting of 7.80 pH

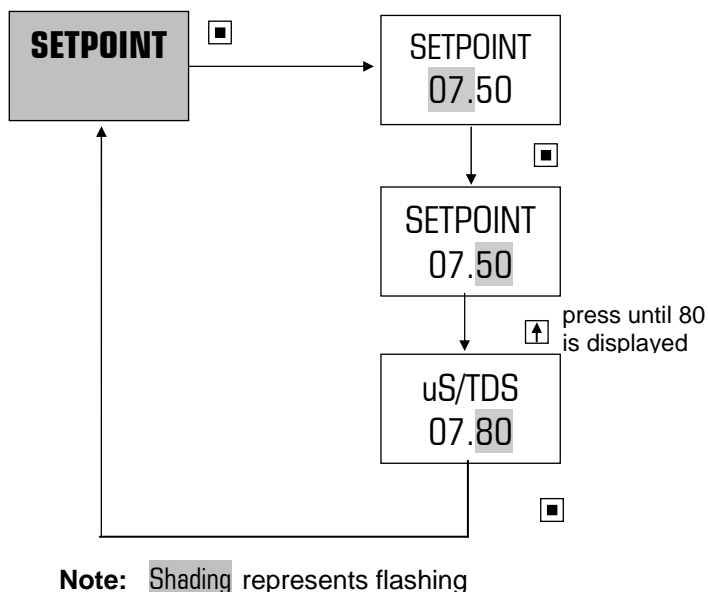
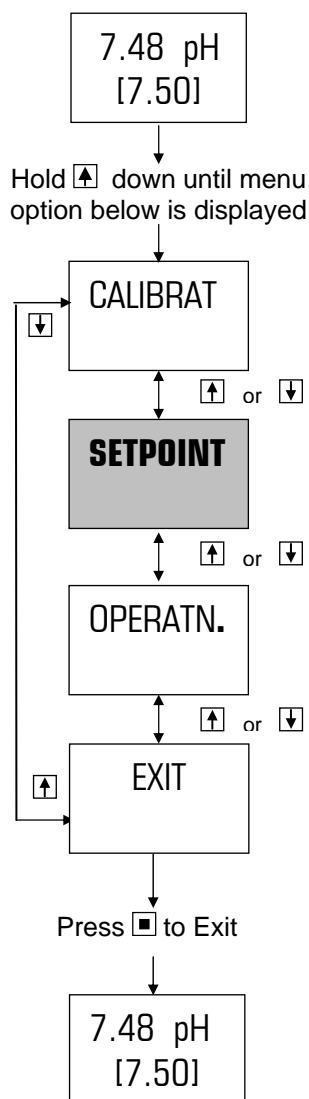

3.4 SET OPERATION

The controller can be programmed to respond to a rise or drop in pH. The controller is factory programmed to operate as a dosing controller, dosing acid via a dosing pump.

The two programmable options are:

Operation: [Acid] (factory default)

Operation: [Base]

Example:
Changing factory default of Acid to Base

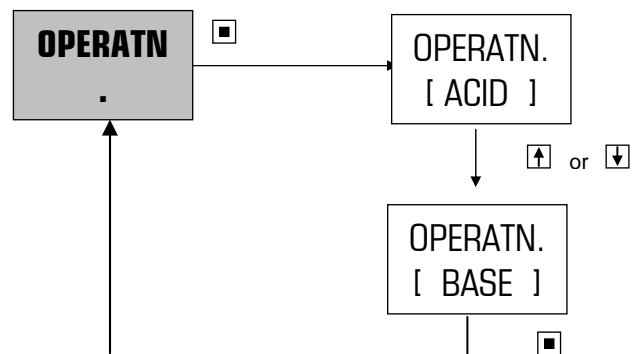
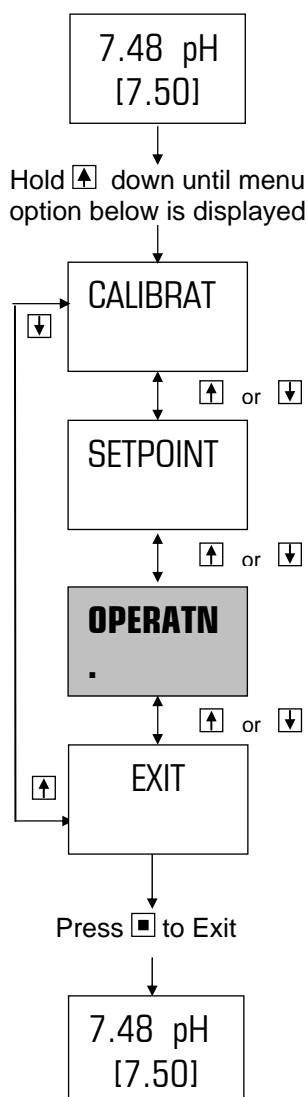

Note: Shading represents flashing

3.5 Testing the Output

The output can be manually operated to test its operation.

Once in test mode, the Output switches on and remains on for 2 minutes or until test mode is cancelled by pressing. ■

Press the ENT pushbutton for a few seconds. The controller will activate the output and the following will be displayed:

7.48 pH O/P: 120

The display shows that the output is activated together with a count-down display. The number below the pH reading shows the remaining ON time in seconds.

When the ENT pushbutton is pressed whilst the count-down is in progress, the controller will exit test mode and will revert back to the normal pH & Setpoint display.

4. FACTORY SETTINGS / PROGRAMMABLE OPTIONS

Item	Factory Setting	Option	Note
Setpoint	7.50 pH	0.01– 14.00 pH (in 0.01 pH increments)	Determine the desired system pH
Operation	ACID	ACID/BASE	ACID: Output activates when pH > Setpoint BASE: Output activates when pH < Setpoint

5. SPECIFICATIONS

Power Supply:	220 – 240 VAC, 50/60 Hz
Inputs:	pH Electrode
Outputs:	240VAC applied to the Output – 5 Amp (resistive) rated. Potential Free contact supplied on request
Resolution of measured pH:	0.01 pH
Hysteresis:	3 % hysteresis fixed
Controller Enclosure rating:	IP55
Operating Temperature:	0 - 50°C